



THE ENGINE PEOPLE

**ENGINE
COMPONENTS
WORLDWIDE**

The image is a composite graphic. The background is a light blue globe with a white grid of latitude and longitude lines. A magnifying glass with a silver handle and a clear lens is positioned in the lower-left quadrant, appearing to inspect the globe. A solid dark blue vertical bar is located on the right side of the image. The word "QUALITY..." is written in a bold, dark blue, sans-serif font across the center of the globe.

QUALITY...

MADE IN GERMANY

With more than 50 years of experience, SECO has an exceptional long tradition in the manufacturing of large bore pistons for 4-stroke Diesel, Gas and Heavy fuel engines. In 1960, the development, design and manufacturing of pistons have been established at our site. Later on, in the 1980's, our company became the leading manufacturer of pistons for large bore diesel engines in the former German Democratic Republic as well as for the East European markets.

After the German reunification in 1990 our company developed to become an approved OEM supplier to several engine makers and their licensees.

Since 2005 we've expanded successfully our activities to other engine core components.

Without the need to take care for any corporate interests, we are

Indebted to our customers only !



**...ALL OVER
THE WORLD**

PISTON

Is it **YOUR** job to ensure trouble-free engine operation?

It is **OUR** job to support you achieving these – probably most important – challenges without compromises.

For that reason, validating the design of our products – in regard to safety, reliability and durability – by using state-of-the-art computer aided calculation methods is the final step in our Pre-Production-Approval-Process.

Only if all these tests have been completed successfully, our products will be released for production.



FIRING PRESSURE



- **composite piston** - nodular cast iron/steel
- **composite piston** - aluminium/steel
- **monoblock piston** - nodular cast iron
- **monoblock piston with ring carrier** - aluminium
- **monoblock piston** - aluminium

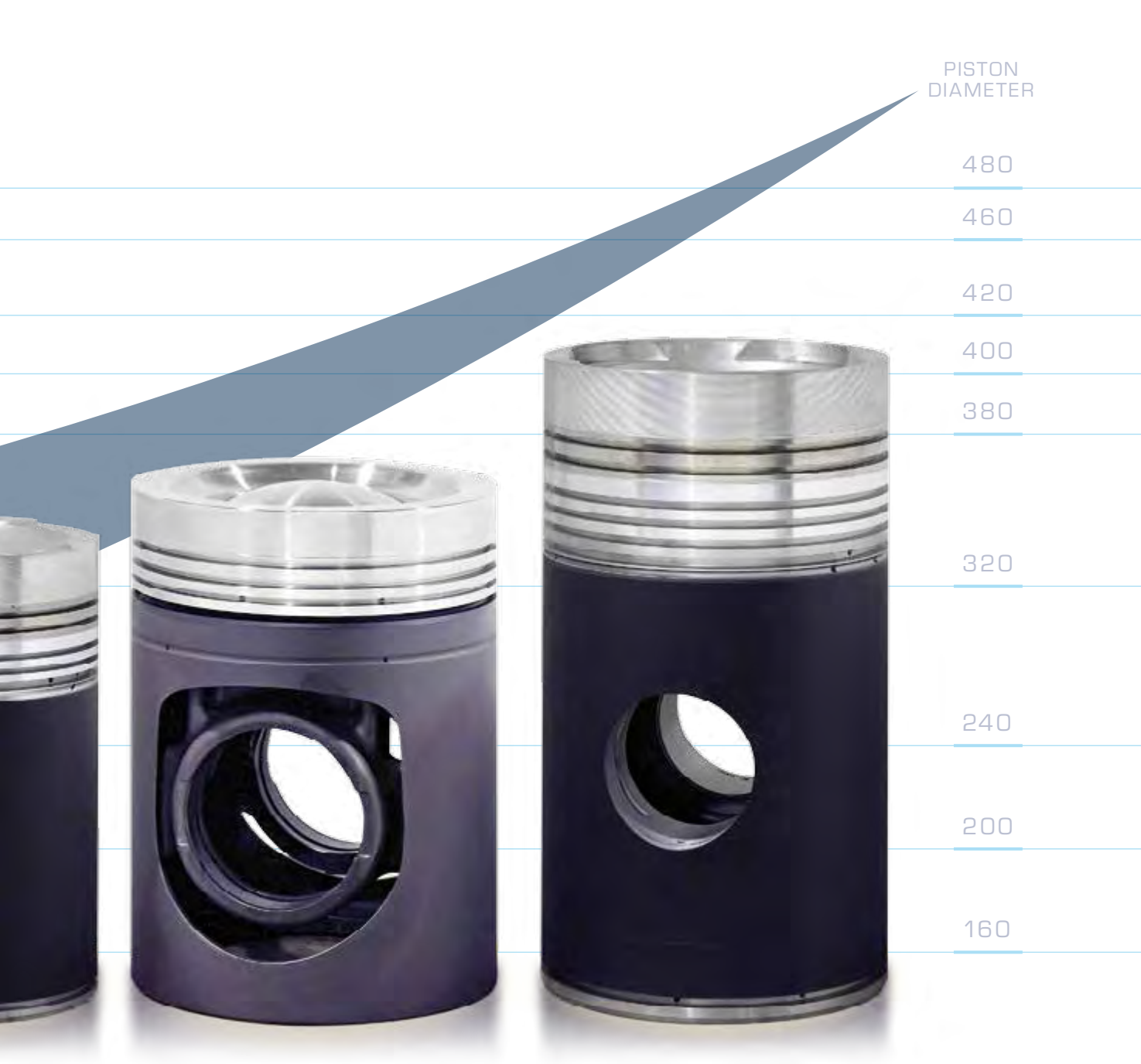

CYLINDER LINER

PRODUCTS





Is it **YOUR** job to reduce operating costs?

Our **(WEAR RESIST)**[®] cylinder liner will give you the advantage to achieve this important objective. We have developed and launched a new generation of cylinder liners with diameters up to 500 mm. For this, a special manufacturing and heat treatment process has been established to increase the operating time considerably. SECO's **(WEAR RESIST)**[®] cylinder liner is your personal tool to work against continuous rising operating costs as well as to preserve your competitive advantage.

Of course, we will also be able to provide with standard cylinder liners in excellent quality.



CONN

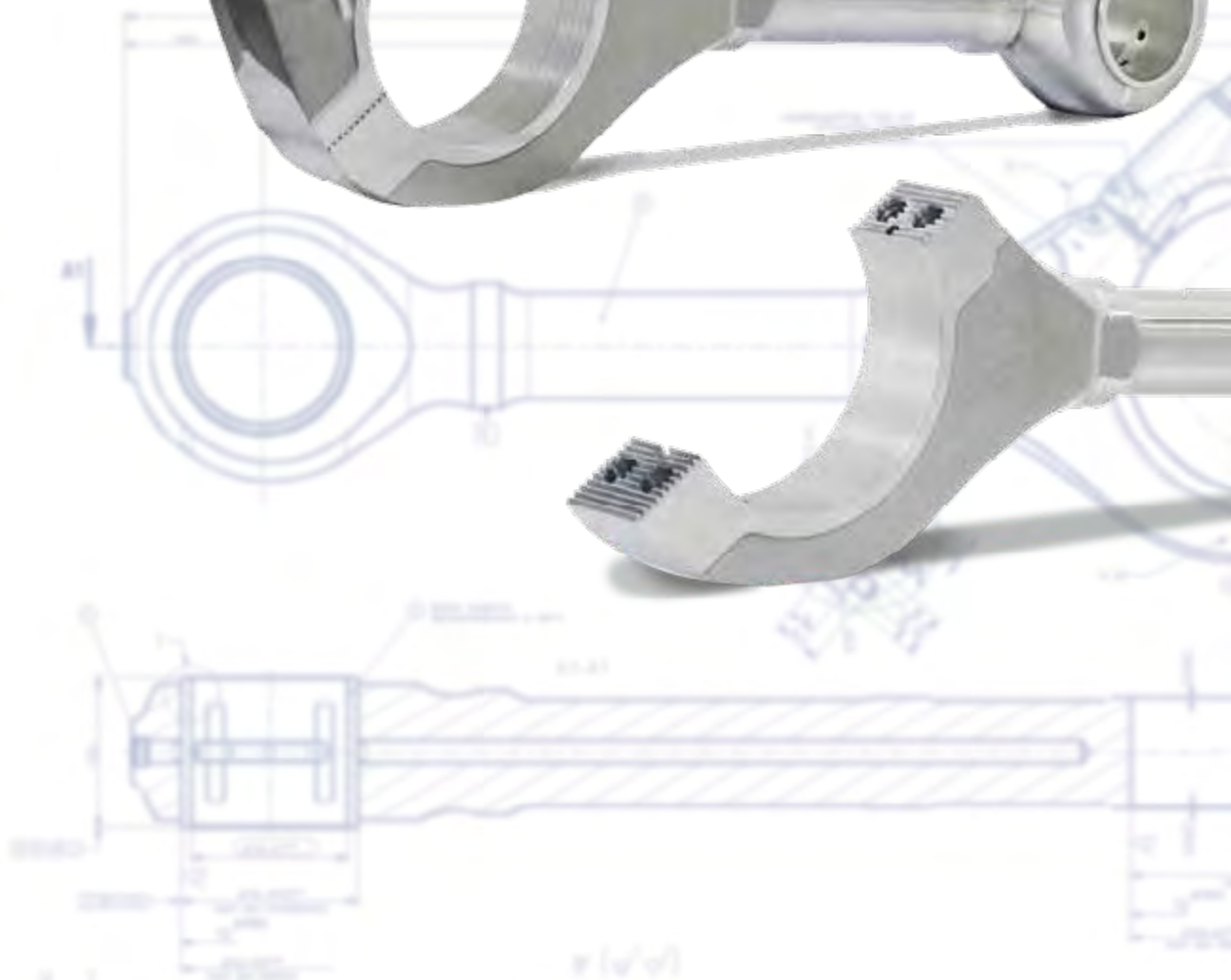

CONNECTING RODS

As one of the most stressed components, the design of connecting rods has special demands. Due to the conversion of linear into rotating motion, the connecting rod is subject to high bending stresses in each operating point. SECO has taken up the challenging task for the development and the manufacturing of connecting rods.

Advanced technologies in each single manufacturing process are applied to support our customers with a reliable and cost effective product.



Developed to take account to the extreme engine operating conditions, SECO's cooled and non-cooled valve seat rings – with various surface coatings and characteristics – are available to provide a reliable solution to our customers.

VALVE



SEAT RINGS



SPARE AND WEAR PARTS

The cheaper the better is **YOUR** strategy in order not to exceed your maintenance budget ?

Those who manage to pay for quality at the right point instead of saving at the wrong point, will be able to avoid recurring spare part costs and major problems in engine operation on medium and long term.

Beside our own production for pistons, cylinder liners and other major spares, we are also able to support you with whatever is needed to cover your requirements for spare and wear parts.

For all those parts we take care that you get what you need:

Reliable spares produced by applying high quality standards as well as the original design and materials.





DEVELOPMENT

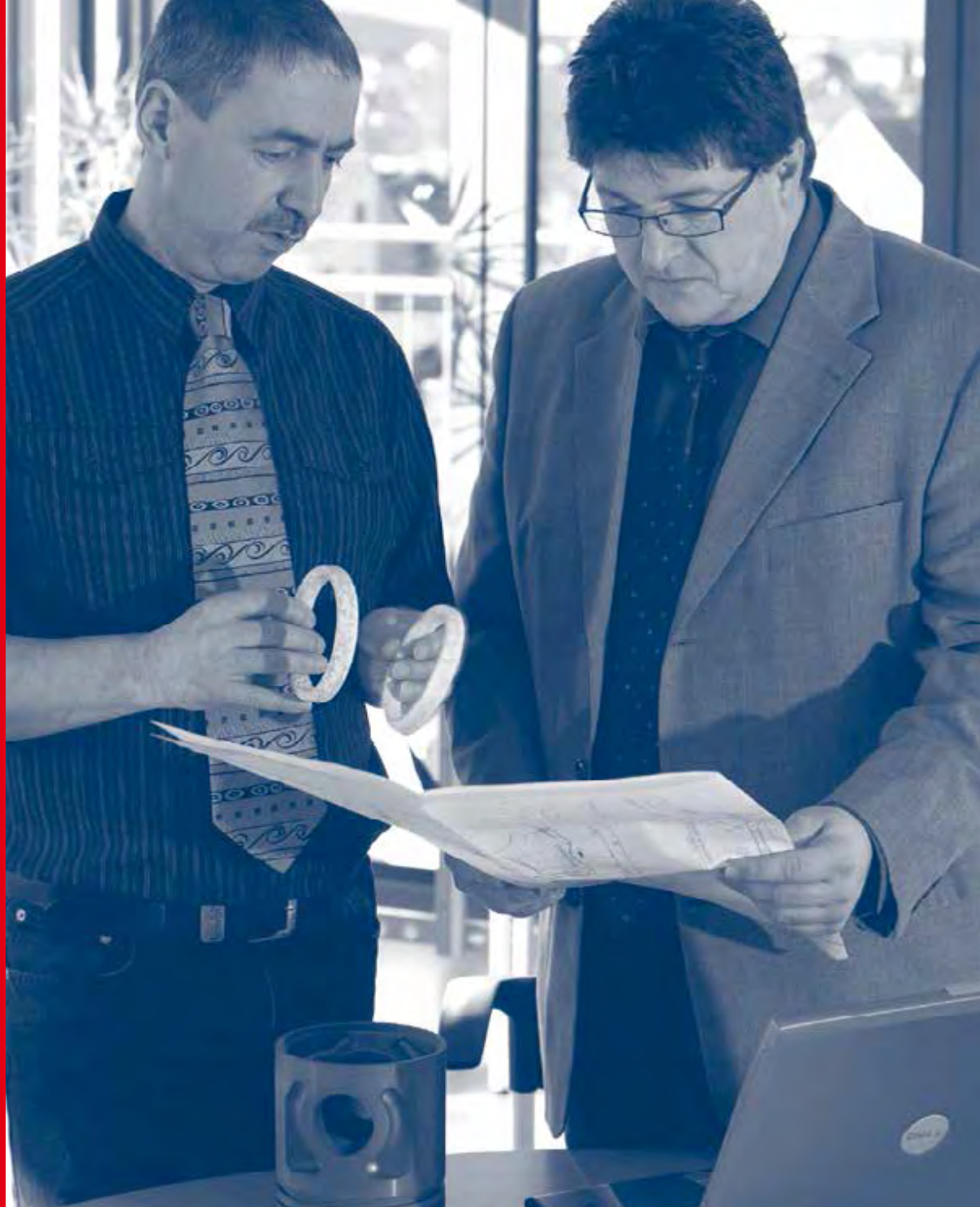

Quality, precision and accuracy for sure by using the most modern technologies



$$p(\alpha) = C \times \cos(\alpha)$$

DEVELOPMENT

Our customer can participate in an experienced and approved network, specialized in solutions to operate and maintain large bore heavy fuel, diesel and gas engines successfully. SECO's team of design engineers, experienced material- and engine specialists is ready to meet the challenges set by our customer's needs and requirements.

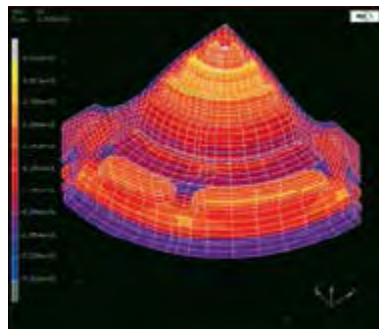
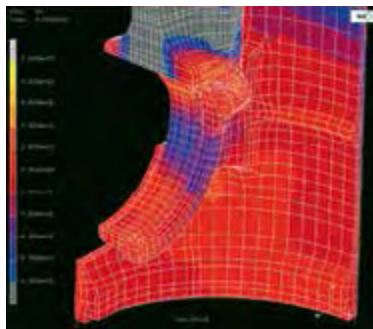
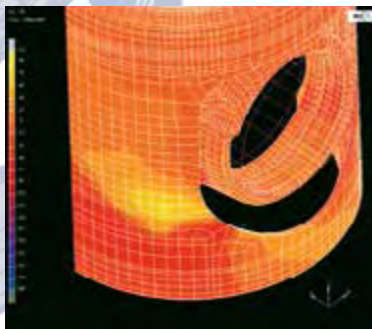

Additional and iterative operating simulations – during the complete design phase – will ensure, that all engine-driven stresses will be taken into consideration, a long time before our parts are in operation.



PRODUCTION

SECO GmbH has been approved by DQS
(Deutsche Gesellschaft zur Zertifizierung von
Managementsystemen)
in accordance to DIN EN ISO 9001:2008.

Our foundry has been approved in accordance
with and under the rules of
**GL-Germanischer Lloyd and
LR-Lloyds Register.**

Certificates of all common Registers can be
provided on customer's request.

PRODUCTION



Various test methods such as magnetic particle crack detection and / or ultrasonic examination are applied. Each single part has to pass these material tests before despatch to the customer.

To meet the requirements of our customers in regard to dimensional accuracy, state-of-the-art machining technology is used.

For us, the induction hardening of the ring-grooves is a well known process to improve lifetime of pistons; as far as Diesel- and / or Gas operation is concerned.

To reduce premature wear of the ring grooves in heavy fuel operation, we are able to support our customers with chrome plated or **(WEAR RESIST)**® treated piston crowns and cylinder liners as well.





COMPANY

SECO GmbH is an independent and privately owned company, located in Germany.

MISSION STATEMENT

Our mission is to serve our customers at the best and to support them with all our experience to solve technical problems in their engine operation. Our main objective is to secure the success of our customers.

Therefore: „Made in Germany“ only

PRODUCTION



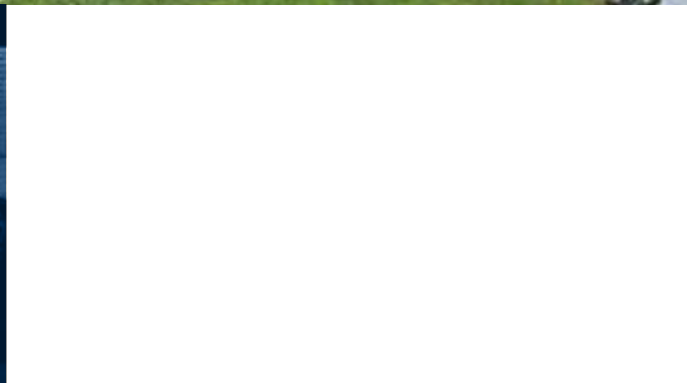

SECO GmbH

GROSS ORDEN 23
06484 QUEDLINBURG (Germany)

www.diesel-engine-motor-service.

